



GREENCITY
WASTE MANAGEMENT EQUIPMENT AND SYSTEMS

Hot dip galvanized steel bins. Capacity: 120L, 240L & 360L



	120L	240L	360L
A (mm)	554	735	880
B (mm)	870	997	1030
C (mm)	480	582	615
D (mm)	930	1070	1110
E (mm)	485	574	590
Weight (Kg)	25	35	44

Technical Data:

- Manufactured from high quality (DC01), deep pressed steel, of appropriate design, to ensure stability and resistance to mechanical stresses.
- Hot dip galvanized, for maximum protection against corrosion.
- Conical shape for ease of discharge.
- EN 4102-1, Fireproof Certified.

Options:

- HDPE injection plastic lid.
- Electrostatically powder coated, for corporate identification and aesthetics.

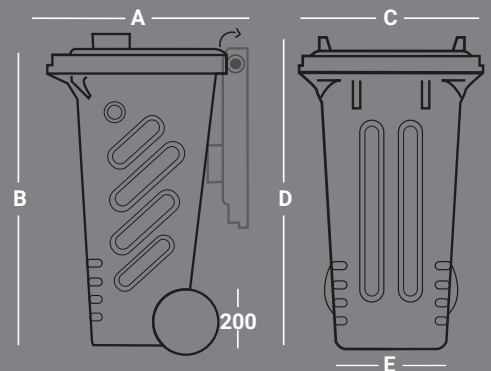

The bins are certified according to EN 840-1/5/6, RAL-GZ 951, EN 4102-1 and tested, *from accredited laboratories.*



Green City International d.o.o

Zrenjaninski put 84v
11210, Belgrade, Serbia

T: +381 11 44 29 210

E: export@gci.co.rs

W: www.green-city.co